

CCS1 TO NACS EV CHARGING ADAPTER

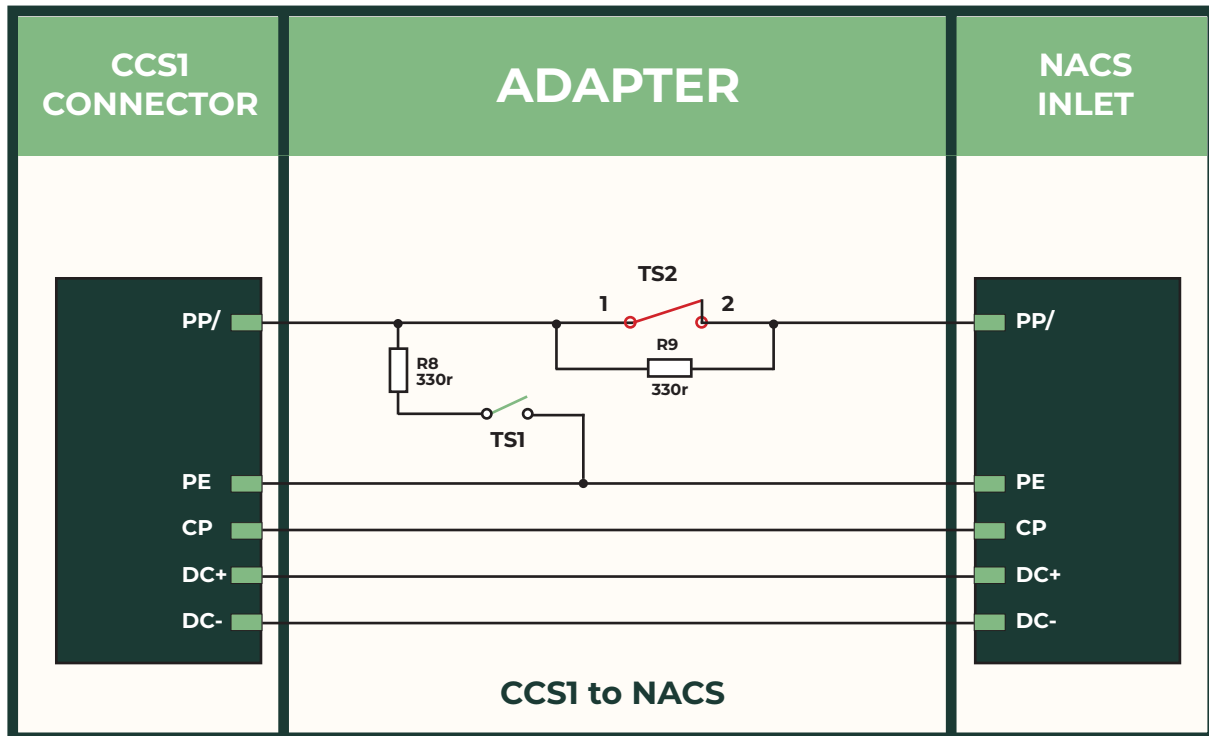

PRODUCT DEFINITION		
Charging Standard	SAE: SAE J1772 Combo (CCS1 DC) SAE: SAE J3400 (NACS)	
Standard / Regulations	IEC: IEC 62196-1 IEC: IEC 62196-2 IEC: IEC 62196-3	
Approvals & Certification	Certified to ANSI / CAN / UL 2252:2025	
Charging Compatibility	DC Fast Charging (Level 3)	
DIMENSIONS OF ADAPTER		
Length	136.0 mm	
Width	68.0 mm	
Height	109.0 mm	
ENVIRONMENTAL SPECIFICATIONS		
Ambient Temperature (Operation)	-30°C to +50°C	
Ambient Temperature (Storage / Transport)	-40°C to +80°C	
Maximum Altitude	3,000 m (above sea level)	
Operating Humidity	Up to 90% RH, Condensing	
Degree of Protection (Mated with Socket / Plug)	NEMA Type 3R	
Degree of Protection (Adapter)	IP67 (unmated at both ends)	
ELECTRICAL AND MECHANICAL PROPERTIES		
Rated Voltage	1,000V DC	
Operating Temperature: -30°C to +50°C	250A (without liquid cooling)	Normal Rated Current
	350A (with liquid cooling)	Maximum Rated Current
Operating Temperature: -30°C to +40°C	380A (without liquid cooling)	Normal Rated Current
	500A (with liquid cooling)	Maximum Rated Current
Maximum Current	500A	
Insulation Resistance	≥ 100 MΩ	
Withstand Voltage	3,000V AC	
Mating Cycles (CCS1 Inlet and NACS Connector)	≥ 10,000 Cycles	
Insertion Force and Withdrawal Force	< 100 N	
MATERIAL		
Adapter Enclosure	Plastic	
Terminal	Copper	
Plating	Silver / Nickel Plating or On Request	
Flammability Rating	UL 94 HB	

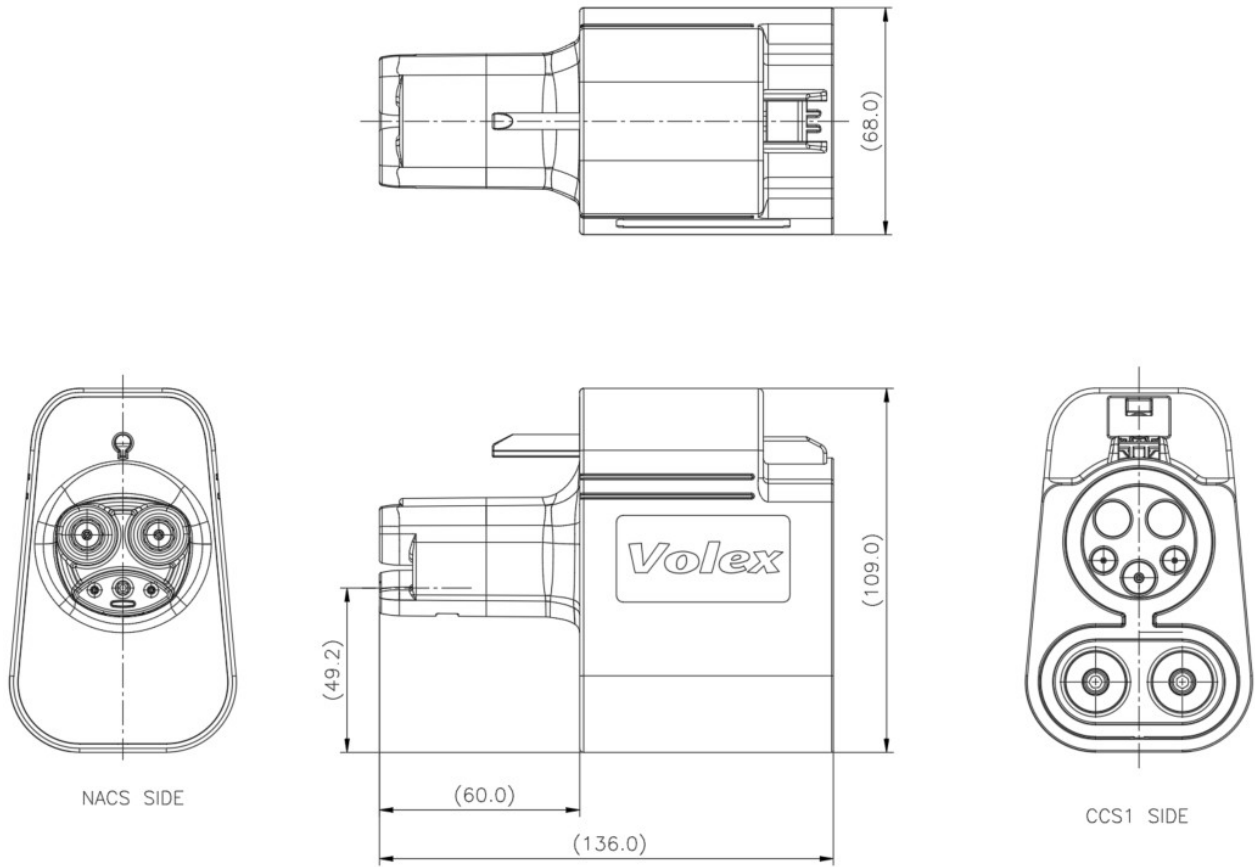

Contact us at sales@volex.com
for assistance in finding the right solution for your needs.